

## Corrosion Protection of Copper by TiO<sub>2</sub> Nanoparticles and Schiff base Coating

M. Behpour\*, S. M. Ghoreishi, M. Salavati-Niasari, N. Mohammadi

Department of Analytical Chemistry, Faculty of Chemistry, University of Kashan, Kashan, I. R. Iran, P. O. Box. 87317-51167, Iran

### Article history:

Received 3/7/2012

Accepted 6/11/2012

Published online 1/12/2012

### Keywords:

Nanoparticles

Titanium dioxide

Corrosion protection

Electrochemical method

Self assembly

### \*Corresponding author:

E-mail address:

m.behpour@kashanu.ac.ir

Phone: +98 361 591 2375

Fax: +98 361 555 2935

### Abstract

The corrosion protection abilities of modified copper in 2-[(Z)-1-{6-[(2-sulfanylphenyl)ethanimidoyl]-2-pyridyl}ethylidene) amino]-1-benzenthio solution containing TiO<sub>2</sub> nanoparticles were evaluated by Tafel polarization and impedance spectroscopy in 3.5% sodium chloride solution. The samples were characterized by energy dispersive X-ray (EDX) and scanning electron microscopy (SEM). The electrochemical results indicated corrosion resistance of this coating depends on the concentration of TiO<sub>2</sub> nanoparticles and assembling time at this solution. After immersing copper for 10 min in Schiff base solution containing 150 mg L<sup>-1</sup> nanoparticles, the coating was able to protect the copper against corrosion about 97%. Results indicated high ability of coating at high temperature and immersing time in sodium chloride solution.

2012 JNS All rights reserved

## 1. Introduction

Copper and its alloys, despite being noble metal corrode significantly in waters containing chloride ions. Extensive use of copper as a structural material in cooling systems of nuclear installations, automobiles, power plants, hotels, oil refineries, sugar factories etc. [1-3], has prompted a thorough research on the corrosion protection of copper in water containing chloride ions. At chloride concentrations lower than 1.0 M, the dissolution of copper surface occurs through

formation of CuCl, which is not protective enough and is converted to the soluble CuCl<sub>2</sub><sup>-</sup>. On the other hand, higher cuprous complexes such as CuCl<sub>3</sub><sup>2-</sup> and CuCl<sub>4</sub><sup>3-</sup> are formed at chloride concentrations higher than 1.0 M [4]. Some methods and compounds have been used for corrosion protection of metal in corrosive solution, such as using of inhibitors [5-8] and organic self-assembled monolayer [9, 10]. Organic self-assembled monolayer (SAMs) has been extensively studied as a means of corrosion

protection because in many cases, the SAMs on the active substrates like copper form densely packed monolayer coatings. SAMs are nanostructures with useful properties. SAMs have typically 1-3 nm thickness but they can be fabricated into patterns having 10-100 nm scale dimensions. SAMs is used as effective barriers for metal protection in corrosive media [10]. Some literatures [11-14] have shown that electrons can penetrate SAMs even though they are defect free. They suggested a corrosion reaction model for the electrode modified by SAMs with defects. The halide ions can permeate through defects and react with metal substrate. Addition of various nanoparticles has been successfully investigated for decrease of defects of coatings. The nanoparticles can be added to the solutions [15-17] and the electrode is simply modified at these solutions for corrosion protection of surface. Because electrons can penetrate SAM, at this work, TiO<sub>2</sub> nanoparticles were added to SN-SAM for higher resistance.

The purpose of this work is to investigate the protection efficiency of 2-[[[(Z)-1-{6-[(2-sulfanylphenyl) ethanimidoyl]-2-pyridyl} ethylidene)amino]-1-benzenthio] self-assembled monolayer (SN-SAM) and coating 2-[[[(Z)-1-{6-[(2-sulfanylphenyl) ethanimidoyl]-2-pyridyl} ethylidene)amino]-1-benzenthio]-TiO<sub>2</sub> nanoparticles (SN-SAM-TiO<sub>2</sub>) on copper corrosion in sodium chloride 3.5% by Tafel polarization, electrochemical impedance spectroscopy and surface analysis.

## 2. Experimental

2-[[[(Z)-1-{6-[(2-sulfanylphenyl)ethanimidoyl]-2-pyridyl} ethylidene) amino]-1-benzenthio] solution ( $5 \times 10^{-3}$  M) were prepared by dissolving of accurate amount of SN Schiff base in ethanol

96%. The SN Schiff base solution containing TiO<sub>2</sub> nanoparticles were prepared by dissolving of accurate amount of SN Schiff base in ethanol 96% and adding 50, 100, 150 and 200 mg L<sup>-1</sup> titanium dioxide nanoparticles to solution and sonicating of solution for 15 min. The electrochemical measurements were conducted by AUTOLAB model PGSTAT35 with three electrode cell with; silver-silver chloride (Ag/AgCl (3 M Cl<sup>-</sup>)) as a reference electrode, plate platinum as a counter electrode and substrate of copper (1 cm × 1 cm × 0.1 cm) with purity of ≥99.9 wt.% as a working electrode. The copper electrode was abraded by emery papers with different grades (360, 400, 800, 1000, 1200 and 2000), then sonicated in deionized water and ethanol for 2 min. Again, electrode was sonicated with deionized water. After preparing working electrodes, the copper electrodes were immersed in the SN-SAM solution and SN-SAM+TiO<sub>2</sub> solutions immediately after sonicating for 10 and 20 min assembling time and various concentrations of nanoparticles (50, 100, 150 and 200 mg L<sup>-1</sup>) for forming coatings. The polarization studies (effect of nanoparticles concentration and self assembling time, immersion time and temperature of corrosive media (0.5, 6.0 and 12.0 h)) were carried out in sodium chloride solution by the scan rate of 0.5 mV s<sup>-1</sup> from -200 to +200 mV relative to the corrosion potential. Obtained data were analyzed using Nova 1.6.013 electrochemical software. The temperature were adjusted to 298-328 K using TAMSON model T1000 thermostat. The impedance measurements (effect of nanoparticles concentration and self assembling time) were carried out in the frequency range of 100 kHz to 0.1 Hz under excitation of a sinusoidal wave of 10 mV in room temperature. The impedance data were analyzed with Nova 1.6.013 software and fitted to the appropriate equivalent

circuits. Images of the coatings were acquired by scanning electron microscopy. The coatings were characterized with scanning electron microscopy (SEM) and energy dispersive X-ray (EDX) spectrums.

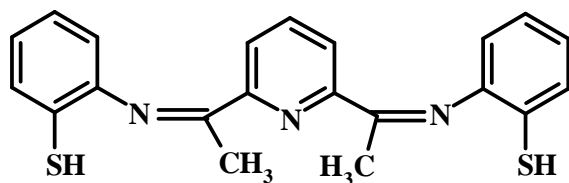

Fig. 1. Structure of Schiff base

### 3. Results and discussion

#### 3.1. Electrochemical impedance spectroscopy

The corrosion inhibiting properties of copper electrode modified in SN-SAM and SN-SAM-TiO<sub>2</sub> at various concentrations of nanoparticles and 10 and 20 min assembling time in sodium chloride was investigated by impedance method. The results have been shown in Fig. 2 and Table 1.

The impedance data of bare copper electrode was fitted with an equivalent circuit as shown in Fig. 3-a, Warburg impedance ( $Z_w$ ) that is in series with the charge transfer resistance ( $R_{ct}$ ) and both are generally in parallel with the constant phase element ( $CPE$ ), and all of them are in series with the solution resistance ( $R_s$ ). The Warburg impedance reflects the anodic diffusion process of soluble copper species ( $CuCl^{-2}$ ) from the surface of the electrode to the bulk solution and the cathodic diffusion process of dissolved oxygen from the bulk solution to the surface of the electrode [18].

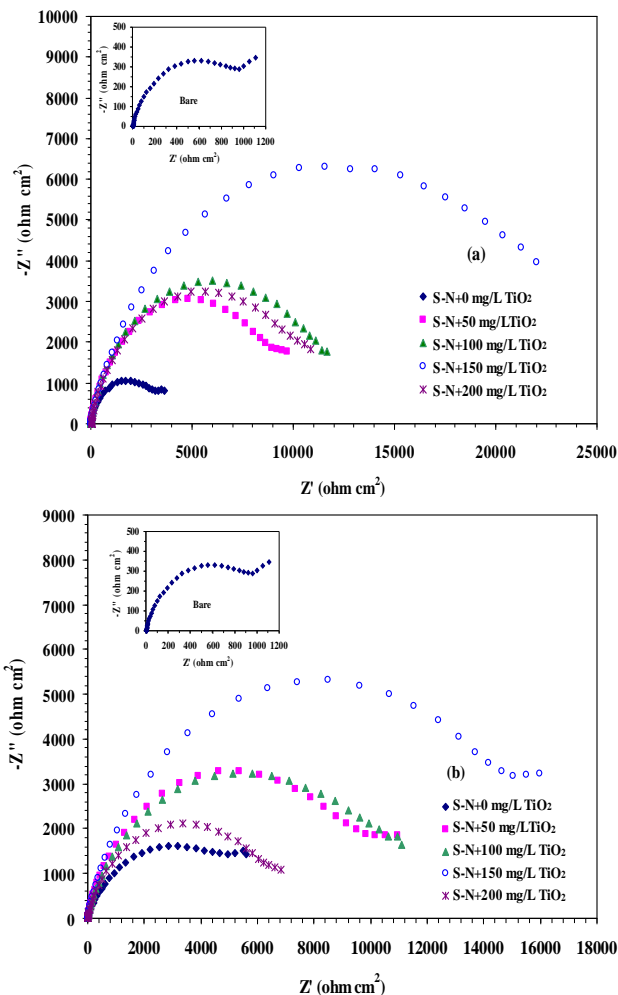
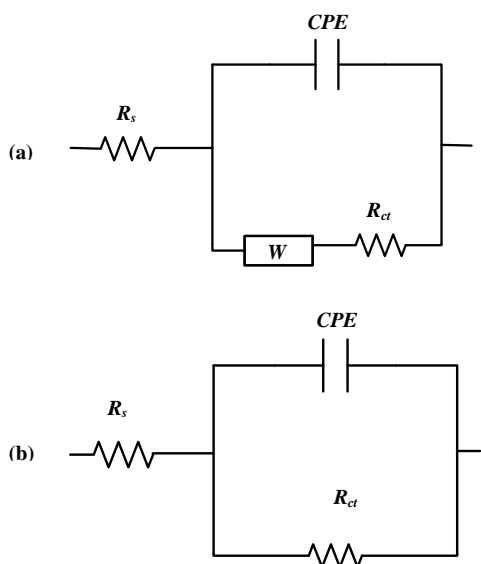

Fig. 2. Nyquist plots of copper electrode modified for (a) 10 min (b) 20 min assembling time in SN-SAM-TiO<sub>2</sub> in sodium chloride solution

The Nyquist plots show there are differences at size and shape of Nyquist plots of modified copper electrodes than bare copper electrode. The figures show that there isn't Warburg impedance in presence of coatings and a high charge transfer resistance ( $R_{ct}$ ) was seen for the coatings incorporated with nanoparticles. The Warburg impedance observed in bare disappears from the Nyquist plots of SN-SAM-TiO<sub>2</sub> coating, reflecting that the coating have good inhibition effect and they can prevent the diffusion processes. The impedance plots of copper modified with coating

were fitted (Fig. 3-b) by  $R_s$ ,  $R_{ct}$  and  $CPE$ .



**Fig. 3.** Equivalent circuit of the copper (a) without coating (b) with coatings.

$R_s$  shows the solution resistance and  $R_{ct}$  shows the charge transfer resistance and  $CPE$  is constant phase element instead of a ideal double layer capacitor for more accurate fit. The impedance function of a  $CPE$  is defined by the mathematical expression:

$$Z_{CPE} = [Y_0(j\omega)^n]^{-1} \quad (1)$$

where  $Y_0$  is the magnitude of the  $CPE$ ,  $n$  the  $CPE$  exponent (phase shift),  $\omega$  the angular frequency ( $\omega = 2\pi f$ , where  $f$  is the AC frequency), and  $j$  here is the imaginary unit. The correction of capacity to its real values was calculated from following equation [19]:

$$C_{dl} = Y_0(\omega_{max})^{n-1} \quad (2)$$

where  $\omega_{max}$  is the frequency at which the imaginary part of impedance ( $-Z''$ ) has a

maximum. The percentage inhibition efficiency ( $\eta$ ) was calculated using the following equation [20]:

$$\eta = \frac{R_{ct} - R_{ct}^{\circ}}{R_{ct}} \times 100 \quad (3)$$

where  $R_{ct}^{\circ}$  and  $R_{ct}$  are the charge transfer resistance in absence and presence of coating, respectively. In order to investigate the influence of assembling time on the protective properties of the coating, the coating were prepared in 10 and 20 min immersion time. Table 1 shows the values of  $\eta$  and other obtained electrochemical parameters from Nyquist plots. The results of Table 1 indicate the highest impedance values are found at 150 mg L<sup>-1</sup> of nanoparticles incorporation for 10 min assembling time. This is why, the assembling time wasn't increased and assembling time was stopped until 20 min.

Fig. 2 clearly indicates that the polarization resistance values increases and then decreases when the content of nanoparticless increases. The best results were obtained at 150 mg L<sup>-1</sup> of nanoparticles incorporation for 10 min assembled. This effect suggests the presence of the nanoparticles in coating that covers the defects of SN-SAM. But the excessive amount of TiO<sub>2</sub> nanoparticles gives serious aggregation among nanoparticless [21]. For the coatings were modified by 50, 100 and 150 mg L<sup>-1</sup> of TiO<sub>2</sub> nanoparticles the resistance values increase, but there is a drop, for the coatings were modified by 200 mg L<sup>-1</sup> of TiO<sub>2</sub> nanoparticles. Investigations show that the both amount of nanoparticles and assembling time have important effects on the barrier properties of the coating.

**Table 1.** Electrochemical impedance analysis data obtained from copper electrode modified at different immersing

time of SN-SAM solution containing various concentrations of TiO<sub>2</sub> nanoparticle in sodium chloride solution

Time (min)	C (TiO <sub>2</sub> ) (mg L <sup>-1</sup> )	R <sub>s</sub> (Ω cm <sup>2</sup> )	R <sub>ct</sub> (Ω cm <sup>2</sup> )	CPE (10 <sup>-6</sup> ; Ω <sup>-1</sup> cm <sup>-2</sup> s <sup>n</sup> )	n	C <sub>dl</sub> (μF cm <sup>-2</sup> )	W (Ω <sup>-1</sup> cm <sup>-2</sup> s <sup>0.5</sup> )	η
Bare	-	5.9	704	60.5	0.82	55.1	0.002	-
10	0	5.2	3170	28.5	0.806	24.4	-	77.8
	50	4.9	8430	6.62	0.843	5.6	-	91.6
	100	4.1	9860	4.76	0.845	4.1	-	91.7
	150	3.9	18800	4.64	0.780	4.1	-	96.3
	200	6.7	9810	8.76	0.791	7.4	-	92.8
20	0	5.4	5070	22.9	0.756	21.6	-	86.1
	50	5.1	9150	5.73	0.856	4.9	-	92.3
	100	5.4	9540	5.52	0.819	4.3	-	92.6
	150	5.1	14200	4.52	0.840	4.0	-	95.0
	200	8.7	6100	11.2	0.816	9.2	-	88.5

This trend has been mentioned by some authors [22-24] and has been attributed to this fact that nanoparticles are likely to agglomerate and to create large defects in the coating, therefore increase corrosion activity.

### 3. 2. Tafel polarization investigation

In this section, corrosion protection of copper electrode modified in SN-SAM-TiO<sub>2</sub> solution at various concentrations of nanoparticles at 10 and 20 min assembling time for forming coatings at 298 K in 3.5% sodium chloride solution can be observed by corrosion current. Fig. 4 indicates the Tafel curves of bare and modified copper decrease to 5.94 μA cm<sup>-2</sup>, and when the copper was modified with SAM solution containing 150 mg L<sup>-1</sup> nanoparticles for 10 min, *i*<sub>corr</sub> decreases to 1.04 μA cm<sup>-2</sup>, which indicates corrosion current remarkably decreases in presence of coatings. Enhanced corrosion protection effect of SN-SAM-TiO<sub>2</sub> nanocomposite can be because of inertness of TiO<sub>2</sub> in an electrochemical environment; principally because TiO<sub>2</sub> has dielectric property,

electrodes in sodium chloride solution. The polarization parameters obtained by the Tafel extrapolation method have been listed in Table 2. The percentage inhibition efficiencies were calculated using the following equation [25]:

$$\eta = \frac{i_{corr}^{\circ} - i_{corr}}{i_{corr}^{\circ}} \times 100 \quad (4)$$

where *i*<sub>corr</sub><sup>o</sup> and *i*<sub>corr</sub> are the corrosion current in absence and presence of coating, respectively. The corrosion current and corrosion potential of coatings on copper were found to decrease with increasing of TiO<sub>2</sub> until 150 mg L<sup>-1</sup>. For the bare copper electrode in sodium chloride solution the *i*<sub>corr</sub> is 38.30 μA cm<sup>-2</sup>, when the copper was modified with SN-SAM solution for 10 min, *i*<sub>corr</sub> high bond energy, and lattice this coating can prevent the anodic dissolution process [26]. Moreover S atoms can be bonded to the Ti rows or O vacancies in the bridging oxygen rows. The O2p+Ti3d are valance bond, which are ideal for electron donor interactions with S [27].

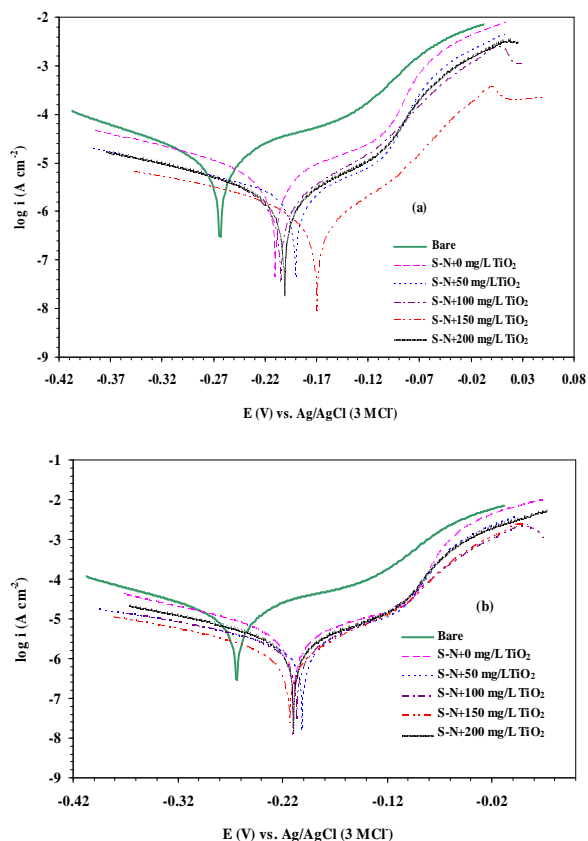

**Fig. 4.** Tafel polarization plots of copper electrode modified for (a) 10 min (b) 20 min assembling time in SN-SAM-TiO<sub>2</sub> in sodium chloride solution.

As clearly seen in Table 2, the corrosion potential of the coating was more positive than the bare. In the literature [28, 29], it has been reported that if displacement in corrosion potential is less than 85 mV, the inhibitor can be seen as mixed type; and if the displacement in corrosion potential is bigger than 85 mV from corrosion potential of bare, the inhibitor can be seen as a cathodic or anodic type. At this work, the prepared coating have displacement lower than 85 mV, but for best coating with high inhibition efficiency there is 95 mV displacement. These results show the prepared coating at 150 mg L<sup>-1</sup> nanoparticle for 10 min assembling time has more effect on protecting of anodic dissolution.

For investigation of effect immersion time in sodium chloride solution polarization curves of coating at various immersion times were shown at Fig. 5. It is clear that both the cathodic and anodic reactions were inhibited. The corresponding electrochemical parameters including corrosion potential, Tafel slopes, corrosion current and inhibition efficiency have been given in Table 3. It is evident from obtained results the coating indicates inhibition efficiency 96.1% even after 12.0 h immersion in corrosive media. The results indicate performance of coating hasn't been shown significant change with increasing in immersion time.

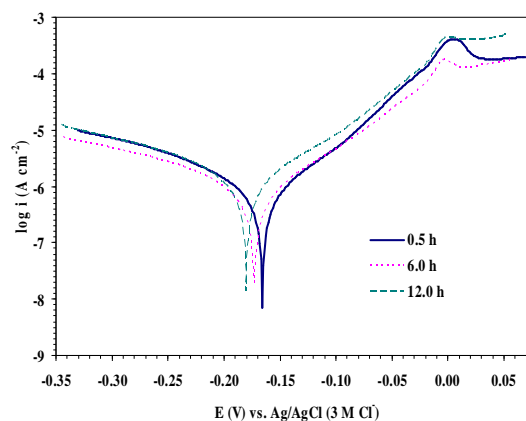

**Fig. 5.** Tafel polarization plots copper electrode modified for 10 min in SN-TiO<sub>2</sub> (150 mg L<sup>-1</sup>) in sodium chloride solution.

**Table 2.** Electrochemical Tafel parameters of copper electrode modified at 10 and 20 min assembling time of SN-SAM-TiO<sub>2</sub> in sodium chloride solution

Time (min)	C (TiO <sub>2</sub> ) (mg L <sup>-1</sup> )	-E <sub>corr</sub> vs. Ag/AgCl (3 M Cl <sup>-</sup> ) (mV)	-b <sub>c</sub> (mV dec <sup>-1</sup> )	b <sub>a</sub> (mV dec <sup>-1</sup> )	i <sub>corr</sub> (μA cm <sup>-2</sup> )	η
Bare	-	265	187	526	38.30	-
10	0	210	182	110	5.94	81.9
	50	190	142	97	5.10	86.7
	100	204	177	113	3.76	90.2
	150	170	147	113	1.04	97.3
	200	202	175	119	3.86	89.9
20	0	179	221	349	5.39	85.9
	50	201	275	117	4.59	88.0
	100	206	252	151	3.95	89.7
	150	213	169	112	1.60	95.8
	200	210	286	240	6.31	83.6

**Table 3.** Electrochemical impedance analysis data of copper electrode modified for 10 min assembling time in SN-SAM-TiO<sub>2</sub> solution containing 150 mg L<sup>-1</sup> TiO<sub>2</sub> nanoparticle for different immersion time in sodium chloride solution.

Time (h)	-E <sub>corr</sub> vs. Ag/AgCl (3 M Cl <sup>-</sup> ) (mV)	-b <sub>c</sub> (mV dec <sup>-1</sup> )	b <sub>a</sub> (mV dec <sup>-1</sup> )	i <sub>corr</sub> (μA cm <sup>-2</sup> )	η
0.5	170	147	113	1.04	97.3
6.0	173	143	223	1.23	96.8
12.0	180	111	138	1.49	96.1

### 3. 3. Effect of temperature

At this part, the influence of solution temperature on inhibition efficiency of SN-SAM-TiO<sub>2</sub> coating was shown by Tafel polarization. To investigation of effect temperature on the coating, it was prepared for 10 min assembling time in SN solution containing 150 mg L<sup>-1</sup> TiO<sub>2</sub> nanoparticles and was immersed in sodium chloride media for

30 min in the range of 298–328 K (Fig. 6). It was observed that corrosion current and inhibition efficiency increase with increasing of temperature. The increase in inhibition efficiency with increasing temperature can be attributed to strong adsorption of the coating to surface [20]. The results of Table 4 suggest coating has high corrosion protection at high temperature of corrosive media.

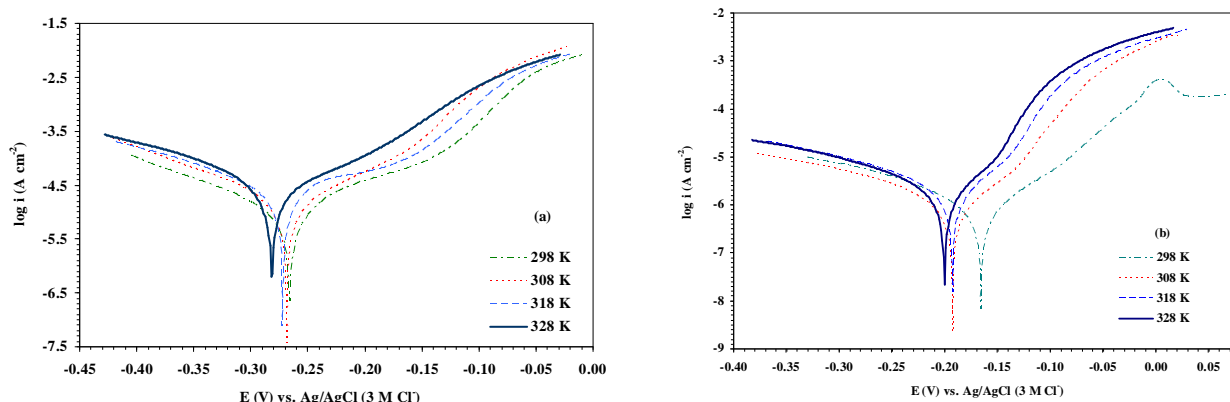

**Fig. 6.** Tafel polarization plots copper electrode modified for 10 min assembling in SN-SAM-TiO<sub>2</sub> (150 mg L<sup>-1</sup>) in different temperature of sodium chloride solution

**Table 4.** Electrochemical parameters of copper electrode modified for 10 min assembling in SN-SAM-TiO<sub>2</sub> (150 mg L<sup>-1</sup>) in different temperature of sodium chloride solution

<i>T</i> (K)	<i>E<sub>corr</sub></i> vs. Ag/AgCl (3 M Cl) (mV)	<i>-b<sub>c</sub></i> (mV dec <sup>-1</sup> )	<i>b<sub>a</sub></i> (mV dec <sup>-1</sup> )	<i>i<sub>corr</sub></i> (μA cm <sup>-2</sup> )	<i>η</i>
Bare					
298	265	187	526	38.30	-
308	268	306	291	67.57	-
318	272	312	577	109.29	-
328	282	405	246	132.10	-
coating					
298	170	147	113	1.04	97.3
308	192	114	168	1.48	97.8
318	193	89	149	2.33	97.9
328	200	86	146	2.39	98.2

### 3. 4. Surface analysis

The surface morphology and composition of the coatings were determined by scanning electron microscopy and energy-dispersive X-ray spectrometry. Fig. 7 (a-b) shows SEM images of SN-SAM and SN-SAM-TiO<sub>2</sub> coating. Fig. 8 indicates SEM images of copper without coating and SN-SAM-TiO<sub>2</sub> coating was immersed in sodium chloride solution for 8.0 h. SEM image of

copper without coating was immersed in corrosive solution show effect of attack of ions to copper surface. Comparison of Fig. 7-b with Fig. 8-b show that there are little change after washing the samples in water and ethanol and immersing electrode for 8.0 h at sodium chloride solution. These results indicate the titanium were strongly attached to the electrode (Fig. 7-b). The elemental distribution of SN-SAM-TiO<sub>2</sub> was investigated by



energy dispersive X-Ray method. EDX spectrums indicated presence of titanium in coating SN-SAM-TiO<sub>2</sub> (Fig. 9-b) than SN-SAM (Fig. 9-a).

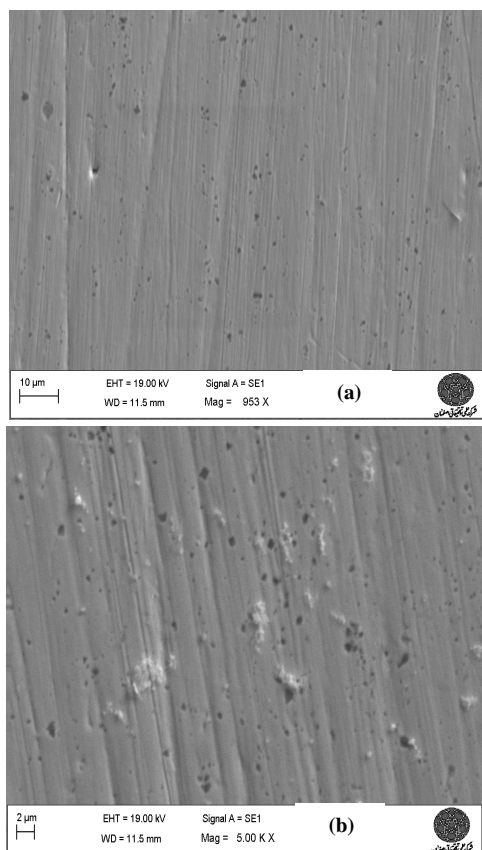

**Fig. 7.** SEM images of copper with a) SN-SAM coating, b) SN-SAM-TiO<sub>2</sub> coating

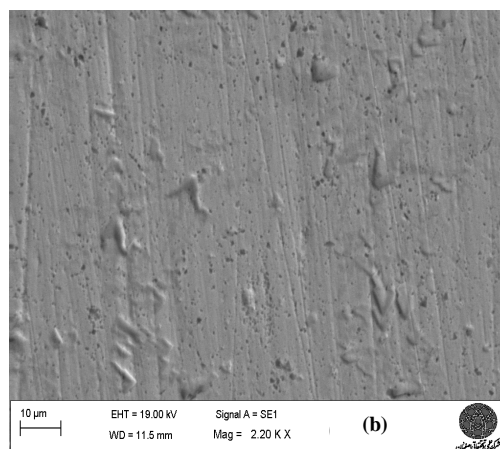
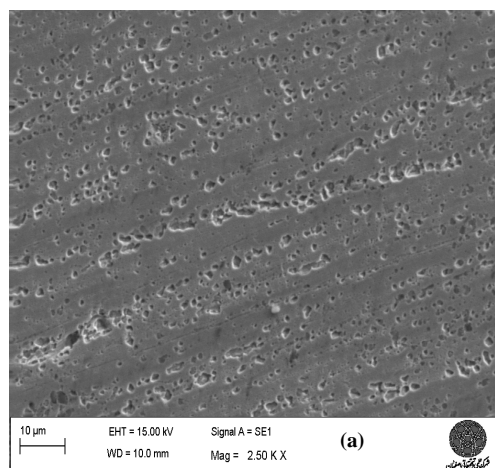

**Fig. 8.** SEM images of copper a) without coating after 8.0 h immersing in sodium chloride 3.5%, b) with SN-SAM-TiO<sub>2</sub> coating after 8.0 h immersing in sodium chloride 3.5%

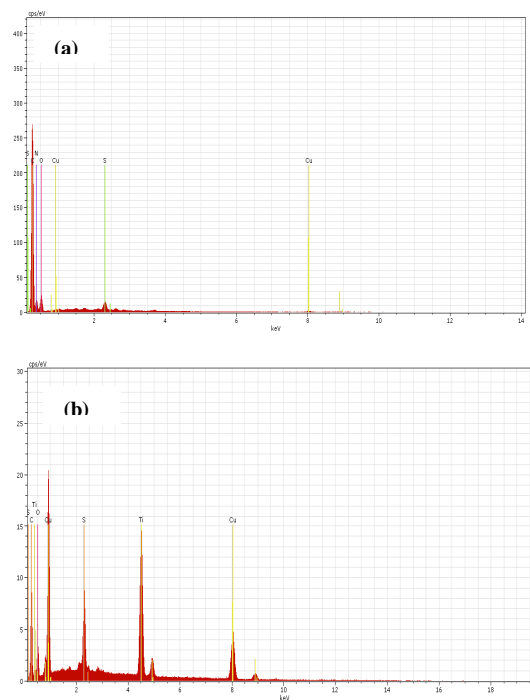

**Fig. 9.** EDX spectrums of copper a) with SN-SAM coating, b) with SN-SAM-TiO<sub>2</sub> coating

#### 4. Conclusion

The SN solution containing 150 mg L<sup>-1</sup> TiO<sub>2</sub> nanoparticles indicated good resistance for copper corrosion in sodium chloride media. Obtained results suggested that the both amount of

nanoparticle and immersing time are important parameters on the inhibition efficiency of prepared coating. The electrochemical indicated high ability of coating even at high temperature and immersing time in sodium chloride media. The EDX analysis and SEM image showed presence of titanium at coating and SEM image confirmed good performance of coating containing SN Schiff base and TiO<sub>2</sub> nanoparticles with preparation at short time.

### Acknowledgements

The authors are grateful to University of Kashan for supporting this work by Grant No.15919527.

### References

- [1] M.M. Singh, R.B. Rastogi, B.N. Upadhyay, M. Yadav. *Mater. Chem. Phys.* 80 (2003) 283–293.
- [2] M. Behpour, N. Mohammadi. *Chem. Eng. Comm.* 200 (2012) 1-16.
- [3] E.M. Sherif, S.M. Park. *Corros. Sci.* 48 (2006) 4065-4079.
- [4] M. Behpour, N. Mohammadi. *Corrosion*. DOI: <http://dx.doi.org/10.5006/0607>.
- [5] K.C. Emregul, A.A. Akay and O. Atakol. *Mater. Chem. Phys.* 93 (2008) 325-329.
- [6] M. Behpour, S.M. Ghoreishi, N. Mohammadi, N. Soltani, M. Salavati-Niasari. *Corros. Sci.* 52 (2010) 4046-4057.
- [7] M. Behpour, S.M. Ghoreishi, N. Mohammadi, M. Salavati-Niasari, *Corros. Sci.* 53 (2011) 3380-3387.
- [8] F.M. Donahue, K. Nobe. *J. Electrochem. Soc.* 112 (1965) 886-891.
- [9] M. Behpour, N. Mohammadi. *Corros. Sci.* 65, (2012) 331-339.
- [10] Y.Q. Feng, W.K. Teo, K.S. Siow, Z.Q. Gao, K.L. Tan, A.K. Hsieh. *J. Electrochem. Soc.* 144 (1997) 55-64.
- [11] T.M. Nahir, E.F. Bowden. *Electrochim. Acta.* 39 (1994) 2347-2352.
- [12] F.P. Zamborini, R.M. Crooks. *Langmuir.* 14 (1998) 3279-3286.
- [13] L. Sun, R.M. Crooks. *Langmuir.* 9 (1993) 1951-1954.
- [14] O. Chailapakul, L. Sun, C. Xu, R.M. Crooks. *J. Am. Chem. Soc.* 115 (1993) 12459-12467.
- [15] M.F. Montemor, A.M. Cabral, M.G.S. Ferreira. *Surf. Coat. Technol.* 200 (2006) 2875-2885.
- [16] M.F. Montemor, M.G.S. Ferreira. *Prog. Org. Coat.* 63 (2008) 330-337.
- [17] X.H. Chen, C.S. Chen, H.N. Xiao, F.Q. Cheng, G. Zhang, G.J. Yi. *Surf. Coat. Technol.* 191 (2005) 351-356.
- [18] P. Wang, C. Liang, B. Wu, N. Huang, J. Li. *Electrochim. Acta.* 55 (2010) 878-883.
- [19] M. Behpour, S.M. Ghoreishi, N. Soltani, M. Salavati-Niasari. *Corros. Sci.* 51 (2009) 1073–1082.
- [20] M. Behpour, S.M. Ghoreishi, N. Mohammadi, N. Soltani, M. Salavati-Niasari. *Corros. Sci.* 52 (2010) 4046-4057.
- [21] M. Li, Y. Yang, L. Liu, J. Hu, J. Zhang. *Electrochim. Acta* 55 (2010) 3008–3014.
- [22] V. Palanivel, D. Zhu, W.J. van Ooij. *Prog. Org. Coat.* 47 (2003) 384–392.
- [23] L. Liu, J.-M. Hu, J.-Q. Zhang, C.-N. Cao. *Electrochim. Acta* 52 (2006) 538–545.
- [24] M.F. Montemora, M.G.S. Ferreira. *Prog. Org. Coat.* 63 (2008) 330–337.
- [25] M. Behpour, S.M. Ghoreishi, N. Mohammadi, M. Salavati-Niasari. *Corros. Sci.* 53 (2011) 3380-3387.
- [26] N. Padhy, S. Kamal, R. Chandra, U.K. Mudali, B. Raj. *Surf. Coat. Technol.* 204 (2010) 2782–2788.
- [27] J.A. Rodriguez, J. Hrbek, J. Dvorak, T. Jirsak, A. Maiti. *Chem. Phys. Lett.* 336 (2001) 377-384.
- [28] E.S. Ferreira, C. Giacomelli, F.C. Giacomelli, A. Spinelli. *Mater. Chem. Phys.* 83 (2004) 129–134.
- [29] A.K. Satapathy, G. Gunasekaran, S.C. Sahoo, Kumar Amit, P.V. Rodrigues. *Corros. Sci.* 51 (2009) 2848–2856.